

MED X EXERCISE



ARTHUR JONES

HISTORY OF MEDX

Arthur Jones is the legendary founder of Nautilus. In 1986, he founded MedX to perfect the testing of human strength, endurance and range of motion. After years of development and testing, validated by independent research teams at the University of Florida, MedX perfected its medical Lumbar Extension machine. It has since helped tens of thousands of people around the world reduce or eliminate their back pain.

1

Subsequent developments produced the MedX Cervical Extension, Rotary Neck and Torso, and Knee/Hamstring machines, providing the medical community with the first tools capable of producing specific and accurate tests of functional ability, as well as the finest source of rehabilitative exercise.

MedX applied the knowledge gained from its medical machines to the design of a full line of exercise-only machines. These machines incorporated MedX's patented compound weight stack which produces less friction and enables several hundred levels of available resistance in increments of 2ft-lbs. This feature reduces user strain and, for the first time, made it possible for individuals to select the exact level of resistance required regardless of their strength.

In 2002, MedX created exercise versions of its medical machines and branded them the Core Spinal Fitness System.™ In less than 20 minutes, twice a week, these five machines can help reduce or eliminate back pain by focusing on strength, stability, flexibility and endurance of the body's core, providing a solid foundation for whole-body strength.

BIOMECHANICALLY DESIGNED EXERCISE EQUIPMENT

Incorporated into every MedX product are decades of experience and millions of dollars of independent, university-based research. MedX is the most technologically advanced fitness, sports and medical/rehabilitation equipment available. MedX products achieve training efficiency through resistance curves matched to tested and proven strength profiles. They operate at a very low level of friction and offer a choice of resistance in 2-pound increments, ensuring a weight that's just right - not too heavy and not too light - for rapid and steady progress.

Biomechanical precision and low-friction makes MedX state-of-the-art. Engineering excellence and quality components mean that MedX equipment requires virtually no maintenance other than cleaning, and is backed by a 5-year warranty on moving parts and a 10-year warranty on the frame.

WHY MED X

A. 2-Pound Weights: Weight can be increased 2 pounds at a time, simply by inserting a pin.

B. Patented Compound Weight Stack: Base plates of 20 pounds each combine with the upper stack of nine 2-pound plates to accommodate both gradual increases and depending on the exercise up to 1,200 pounds of total resistance.

C. Safer Movement: Every element of the machine's drive train is designed to achieve vertical weight stack movement of only one foot on a full-range repetition; about half of what other equipment produces, reducing inertia and enhancing safety.

D. Reduced User Strain: MedX's unique design places the weight stack approximately 18 inches off the ground, reducing or eliminating the need to bend down to pin the resistance.

E. Low-Friction: Eliminating friction-inducing weight stack guide rods, lowering inertia by shortening weight stack vertical travel to one foot, and using ball bearings throughout the machine produces a smoothness that can't be matched.

F. Low-Maintenance Ball Bearings: MedX only uses high-precision sealed or shielded anti-friction ball bearings that require grease injections about once per year.

G. High-Grade Upholstery: MedX upholstery is made from Boltaflex fabric with a PreFixx protective finish. This easy-care, bacteria-resistant fabric meets Federal Flammability specifications and Life Safety Code Standards while providing the utmost in user comfort and body support. Boltaflex is offered in 12 standard colors selected to blend beautifully with any décor.

H. Quality Materials: All materials used meet the standards of the American Society of Testing and Materials.

I. Painted Heavy-Gauge Steel: MedX products are made with heavy-gauge cold-rolled steel and painted with a smooth powder coated finish. It provides a uniform, durable, high-quality, and attractive finish.



LUMBAR STRENGTH

- Patented, effective pelvic restraint system that keeps gluteus and hamstring muscles from interfering with the targeted exercise area
- Provides isolation of the lumbar spine muscles, increases stability and allows specific, intensive strengthening
- Regular use may help prevent injuries, remedy chronic back pain and contribute to disc hydration

3

LUMBAR STRENGTH



TORSO ROTATION

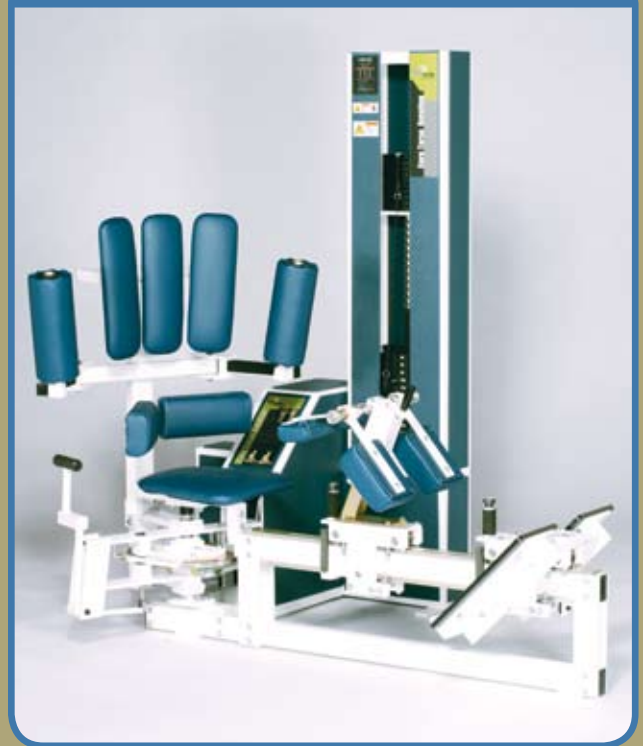

TORSO ROTATION

- Completely isolates waistline muscles
- Unique padded restraint system neutralizes shoulder, arm and chest muscles
- Separate system of padded restraints effectively locks the pelvis and prevents the hip and gluteus muscles from assisting in rotation of the torso
- Increases strength and flexibility at the core of the body, making it a favorite among golf pros looking to increase club head speed

AB ISOLATOR



AB ISOLATOR

- Patented biomechanical design provides the highest possible degree of isolation for abdominal muscles
- Neutralizes hip flexor muscles and restricts arching in the base of the spine—unlike other ab machines
- Provides core abdominal muscle isolation while eliminating the hazard of lower back discomfort for a superior abdominal burn

4-WAY NECK



4-WAY NECK

- Biomechanically precise—trains the flexion and extension muscles of the neck for improved range of motion
- Stretches and strengthens the cervical spinal muscles for decompression of the upper spine while promoting increased omni-directional strength and flexibility of entire neck
- Based on the superior biotechnology of the MedX Medical Neck Extension machine used in spinal rehabilitation facilities around the world

SUPER STRETCH



SUPER STRETCH

- Patented technology places the body into biomechanically advantageous positions for effective stretching
- Seven-stretch program enhances movement around the knee, hip, spine, shoulder, elbow and wrist in addition to stretching seven major muscle groups—including hamstrings and hip adductors
- Hanging stretch facilitates spinal decompression
- Delivers immediate benefits

MED X LOWER BODY

LEG PRESS

- Four-bar linkage movement arm enables maximum gluteus involvement
- Seat back angle adjustment allows balancing range of motion and pressure on back
- Heavily padded seat and shoulder pads for comfort and longevity



LEG PRESS

LEG EXTENSION

- Seat designed to maximize efficiency of exercise and to ensure proper joint alignment through the full range of motion
- Movement and seat support design allow for greater range of motion
- Assist handle allows for easy entry into machine
- Goniometer (angle detector) enables observation of proper range of motion



LEG EXTENSION

SEATED LEG CURL

- Movement arm design allows for easy access and proper alignment of the knee joint
- Truncated seat allows support without impeding the hamstrings
- Goniometer (angle detector) enables observation of proper range of motion



SEATED LEG CURL

HIP ABDUCTION



HIP ABDUCTION

- Back pad adjusts to three positions to target specific regions of the abductor muscles
- Comfortable, contoured pads are adjustable and self-aligning for customized fit in machine
- Smooth and low-friction cam follower design
- Seat belt and handgrips maintain body position for isolated hip training

HIP ADDUCTION



HIP ADDUCTION

- Self-adjusting pads on the legs reduce knee shear with primary force proximal to the knee
- Adjustable back pad allows for proper positioning in machine
- Smooth and low-friction cam follower design
- Handles on both sides of the machine assist the user during entry and exit

SEATED CALF



SEATED CALF

- Can be used with bent or straight legs for Soleus or Gastrocnemius emphasis
- Bend allows low pressure and no hyperextension

PRONE LEG CURL



PRONE LEG CURL

- Angled prone positioning provides maximal hamstring workout
- Strategic handles keep body in proper position during use
- Easy to enter and use without adjustments



MED X UPPER BODY

TORSO ARM

- Four-position adjustable handles increase the versatility of the workout
- Arms may be used in unified movement or individually to increase control
- Assist pedal allows pre-stretch and easy start

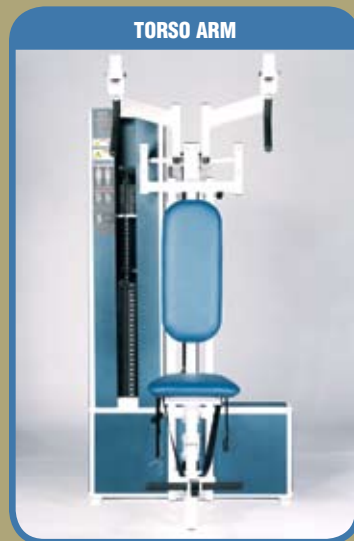

TORSO ARM

OVERHEAD PRESS



OVERHEAD PRESS

- Primary set of handles promotes a slightly forward movement, reducing stress on the shoulders
- Rear handles emulate a military press
- Smooth and low-friction direct steel link design
- Oversized handles for better hand comfort

CHEST PRESS

- Movement converges at the end of the stroke, exercising the pectorals over a wider range of motion
- Synchronized movement arms allow maximum utilization of muscular effort
- Adjustable seat and back pad for optimal positioning
- Strategic designed handles for multiple hand positions



CHEST PRESS

BICEP CURL



BICEP CURL

- Forearm pad aligns movement axes without pressure on chest
- Ergonomically designed handles for natural arm positioning

SEATED ROW



SEATED ROW

- Handles and movement arms mimic the hands' natural movement during the row exercise
- Chest pad adjusts to allow tension at the start of the movement

SEATED DIP



SEATED DIP

- Two position handles for all user sizes
- Smooth and low-friction direct steel link design
- Oversized handles for better hand comfort

TRICEPS EXTENSION



TRICEPS EXTENSION

- Trains the triceps in the contracted position for intense muscle stimulation
- Smooth and low-friction cam follower design
- Fully adjustable shoulder and hand grips to allow isolation of the triceps



MED X UPPER BODY

ARM CROSS

- Adjustable back pad allows ideal shoulder alignment
- Multi-position hand rest for comfort
- Adjustable elbow pads for all sizes



ARM CROSS



LATERAL RAISE

LATERAL RAISE

- Movement arm handles adjust for varying amounts of external rotation
- Movement axes positioned to reduce shoulder stress and bone impingement
- Back pad and seat bottom adjust to ensure proper alignment

PULLOVER

- Angular design allows greater range of motion
- Adjustable seat, back and elbow pads for optimal positioning of user
- Assist pedal allows easy entry into machine

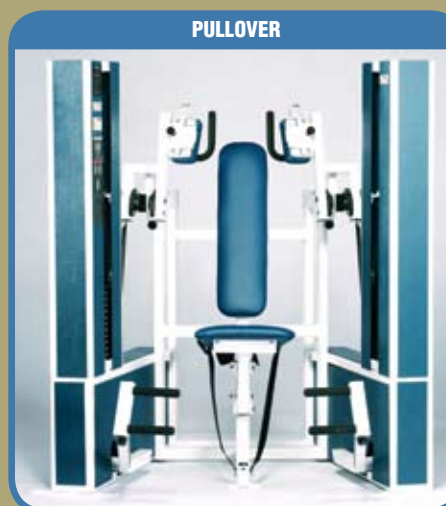

PULLOVER

EQUIPMENT FEATURES

MACHINE TYPE	Total Lbs. Resistance	Resistance Levels	Drive Type	Kevlar Strap	Adjustable Features	Low Friction, Low Inertia Weight Stack	Special Features	Muscle Groups Worked
MEDX CORE								
Lumbar Strength	400	190	direct shaft drive	N	lower body restraint	Y	range of motion start	lumbar muscles
Torso Rotation	300	140	single-axis, bi-directional, cam follower	N	range of motion 90-132°; lower body restraint	Y	automatic accommodating torso restraint	abdominal obliques, latissimus dorsi, serratus
Ab Isolator	300	140	belt link drive	Y	foot board	Y	unique muscle isolation system	hamstrings, abdominal
4-Way Neck	300	140	belt link drive	Y	seat back, seat bottom, range of motion	Y	4 directions of exercises	neck
Super Stretch	N/A	N/A	N/A	N/A	boom angle, leg support, seat back	N/A	multiple, user controlled, repeatable stretches	N/A
MEDX LOWER BODY								
Leg Press	1000	480	belt link drive	Y	seat bottom and back	Y	adjustable footboard	glutes, quadriceps, hamstrings
Leg Extension	500	240	belt link drive	Y	single-leg capability	Y	goniometer (angle detector)	quadriceps
Seated Leg Curl	400	190	belt link drive	Y	single-leg capability	Y	goniometer (angle detector)	hamstrings
Hip Abductor	300	140	direct shaft drive	N	seat back, thigh pads	Y	symmetrical resistance	hips, outer thighs
Hip Adductor	400	190	direct shaft drive	N	seat back, thigh pads	Y	symmetrical resistance	inner thighs
Seated Calf	400	190	belt link drive	Y	seat back	Y	unique calf isolation	calf
Prone Leg Curl	400	190	belt link drive	Y	N/A	Y	N/A	hamstrings, calves
MEDX UPPER BODY								
Torso-Arm	500	240	belt link drive	Y	seat bottom, handle bars	Y	independent arm resistance	upper torso, arms, shoulders
Overhead Press	500	240	direct shaft drive	N	seat bottom, handle bars	Y	extra handles for military press	shoulders, neck, arms
Chest Press	600	140	solid link drive	N	seat bottom and back	Y	non-parallel arm movement	pectorals, deltoids, triceps, biceps
Bicep Curl	300	140	belt link drive	Y	seat bottom, handle bars	Y	forearm support	biceps
Seated Row	500	240	belt link drive	Y	chest pad	Y	non-parallel arm movement	upper back, arms, shoulders
Seated Dip	500	240	direct shaft drive	N	seat bottom, handle bars	Y	N/A	upper torso, arms, shoulders
Triceps Extension	300	140	direct shaft drive	N	seat bottom, handle bars	Y	unique arm position	triceps
Arm Cross	400	190	belt link drive	Y	seat back, arm pads	Y	elbow pads adjust for arm length	pectorals, deltoids
Lateral Raise	300	140	belt link drive	Y	seat bottom, handle bars, arm pads	Y	6-position handle for comfort	deltoids, trapezius
Pullover	600	140	belt link drive	Y	seat back, seat bottom	Y	independent arm resistance	pectorals, triceps, latissimus dorsi

UPHOLSTERY COLORS (Each can be any of the 12 colors below)



FRAME COLORS



SHIELD COLORS



*Colors shown are not guaranteed to be an exact match to actual products. Color samples are available upon request. More color selections are available for an additional charge.

*Additional 100 lb. weight stack can be ordered for an additional charge.



MedX Core Floorspace Configuration

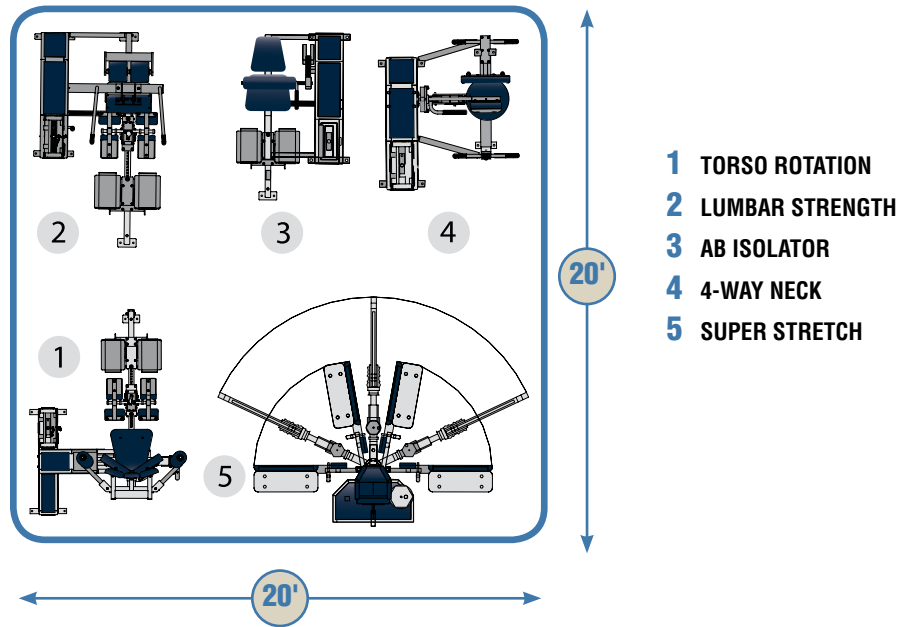

MED X EXERCISE

TO LEARN MORE:

Call toll-free 800.876.6339

- or -

Visit us online at www.MedXOnline.com